

DESIGNER LINE REFRIGERATOR

Model: D1RXN

Natural Refrigerant R-290 Model

Designer Line

1-Section Extra-Wide Reach-In Refrigerator

D1RXN - Stainless steel front, aluminum end panels and interior
D1RXNSA - Stainless steel exterior, aluminum interior
D1RXNSS - Stainless steel exterior and interior



Options and Accessories

(upcharge and lead times may apply)

Stainless steel case back	Casters
Additional epoxy coated steel shelves	Pan slide assemblies
Chrome or stainless steel shelves	Custom laminates
Pass-thru (consult factory)	Special electrical req. (consult factory)
Shallow depth (consult factory)	Correctional Facility Options
Half doors	• One way security screws
Hinged glass door (consult factory)	• Locking hasp (lock not included)
Rehinging of doors (consult factory)	• Stainless steel mesh cover
Wine rack	• Coverless hinges

Consult factory for other model configurations, options and accessories.

Continental
 Refrigerator

Toll-Free: 800-523-7138
 Phone: 215-244-1400
 Fax: 215-244-9579

539 Dunksferry Road
 Bensalem, PA 19020
www.continentalrefrigerator.com

Project Name:

Model Specified:

Location:

Item No:

Quantity:

AIA #:

SIS #:

Standard Model Features

REFRIGERATION SYSTEM

Self contained, performance rated "plug" refrigeration system

Natural, environmentally safe, high efficiency R-290 refrigerant¹

Refrigeration system is readily accessible on top of cabinet, separate from the "food zone"

Automatic, hot gas condensate evaporator

Expansion valve system

CABINET ARCHITECTURE

3" non-CFC polyurethane foam insulation

Smooth, polished chrome workflow door handle

Cam action, lift off hinges

Self-closing door

Magnetic snap-in Santoprene™ door gasket

Cylinder lock in door

Heavy duty pilaster strips

Heavy duty, epoxy coated steel shelves

Adjustable 6" stainless steel legs

MODEL FEATURES

LED interior lighting

Electronic controller with digital display & hi-low alarm

Off-cycle defrost

Top and side air distribution ducts

Cabinet upper side panels and refrigeration "plug" system can be removed and reinstalled at job site

¹ R-290 refrigerant meets all federal and state regulatory requirements.

APPROVAL:

Model Specifications

DIMENSIONAL DATA

Net Capacity (cubic feet)	32 (906 cu l)
Width, Overall (inches)	36 1/4 (921 mm)
Depth, Overall (inches) (including handle)	35 3/8 (899 mm)
Depth (inches) (less door)	32 (813 mm)
Depth (inches) (door open 90°)	66 (1676 mm)
Clear Door Width (inches)	29 5/8 (752 mm)
Clear Door Height (inches)	58 5/8 (1489 mm)
Height, Overall (inches) (including 6" legs)	83 1/4 (2115 mm)
Number of Doors	1
Number of Shelves	3
Shelf Area (square feet)	24.4 (2.3 sq m)

REFRIGERANT DATA

Condensing Unit Size (H.P.)	1/3+
Capacity (BTU per hour)*	2560

ELECTRICAL DATA

Voltage (International)	115/60/1 (220/50/1)
Feed Wires (including ground)	3
Total Amps (International)	6.0 (4.1)
10 ft. Cord/Plug [attached] (International)	Yes (No)

SHIPPING DATA

Height - Crated (inches)	85 1/2 (2172 mm)
Width - Crated (inches)	42 (1067 mm)
Depth - Crated (inches)	42 (1067 mm)
Volume - Crated (cubic feet)	87 (2464 cu l)
Weight Std - Crated (pounds)	440 (200 kg)
Weight SS - Crated (pounds)	462 (210 kg)

* Rating @ +25°F evaporator, 90°F ambient
 Figures in parentheses reflect metric equivalents rounded to the nearest whole unit.



Equipped with one NEMA-5-15P Plug
 (varies by country)

Continental
 Refrigerator

Toll-Free: 800-523-7138
 Phone: 215-244-1400
 Fax: 215-244-9579

539 Dunksferry Road
 Bensalem, PA 19020
www.continentalrefrigerator.com

Due to our continued efforts in developing innovative products, specifications subject to change without notice.



© Copyright 2021. Continental Refrigerator.
 A Division of National Refrigeration & Air Conditioning Products, Inc.

Model Plan Views

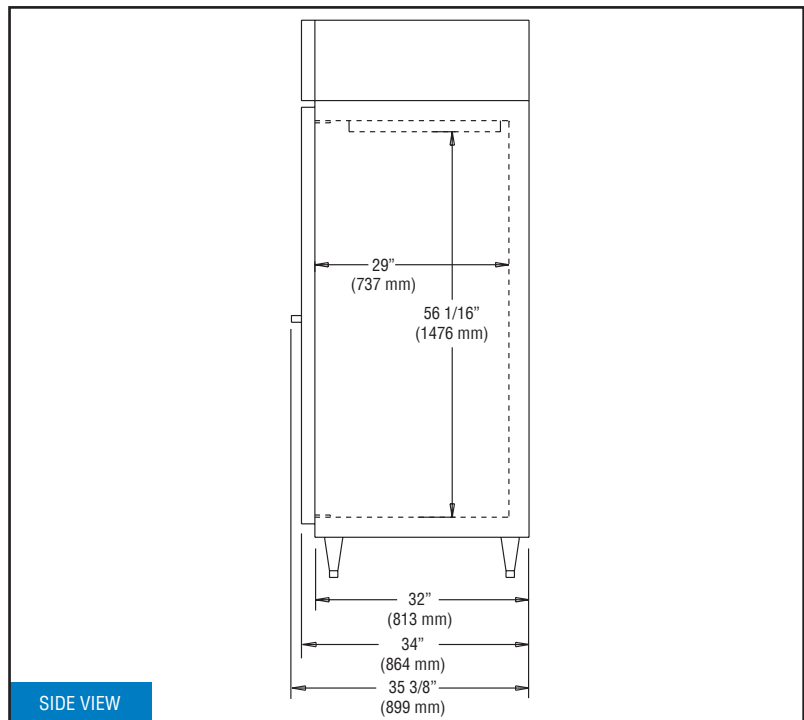
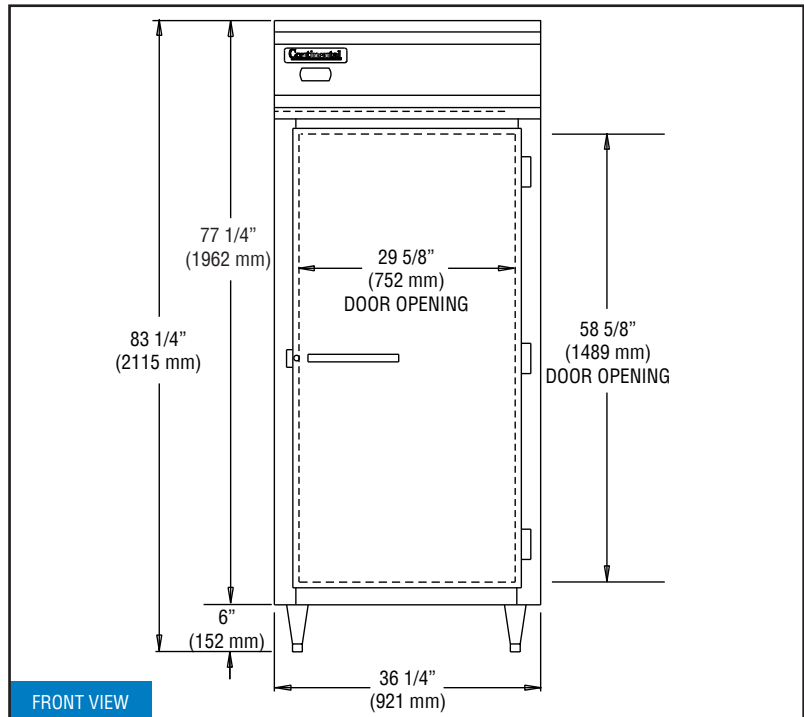

IMPORTANT NOTE: If the cabinet is located directly against a wall and/or under a low ceiling, a minimum clearance of 12" is required on top and 3" on sides and rear.

REVISED: 4/7/2022